

Gerätesteckdose 70°, 10 A, mit Schutzkontakt und Knickschutztülle
Mains appliance line socket 70°, 10 A, with earthing contact and strain relief sleeve



C13

Gewicht / Weight 25 g



Beschreibung / Description

Wiederanschließbare Ausführung für flexible Leitungen, H05VV-F 3G0,75 mm² und 3G1,0 mm², ab 2 m Zuleitungslänge mindestens 3G1,0 mm²

Rewireable, for supply line H05VV-F 3G0,75 mm² and 3G1,0 mm², for lengths over 2 meters minimum 3G1,0 mm²

Abgewinkelte Kabeleinführung rechts

Right angled cable entry

Technische Daten / Specifications

Nennspannung / Rated voltage	250 V~
Nennstrom / Rated current	10 A
Bauart / According to	IEC 60320-1, DIN EN 60320-1
Anschlüsse / Type of terminals	Schraubanschluss / Screw terminals
Kontakte / Material of terminals	CuZn 37, CuZn 38
Kontakträger / Carrying parts	Polyamid 6 / Polyamide 6
Gehäuse / Cover	Polyamid 6 / Polyamide 6
Schutzart / Degree of protection	IP20

Abmessungen / Dimensions

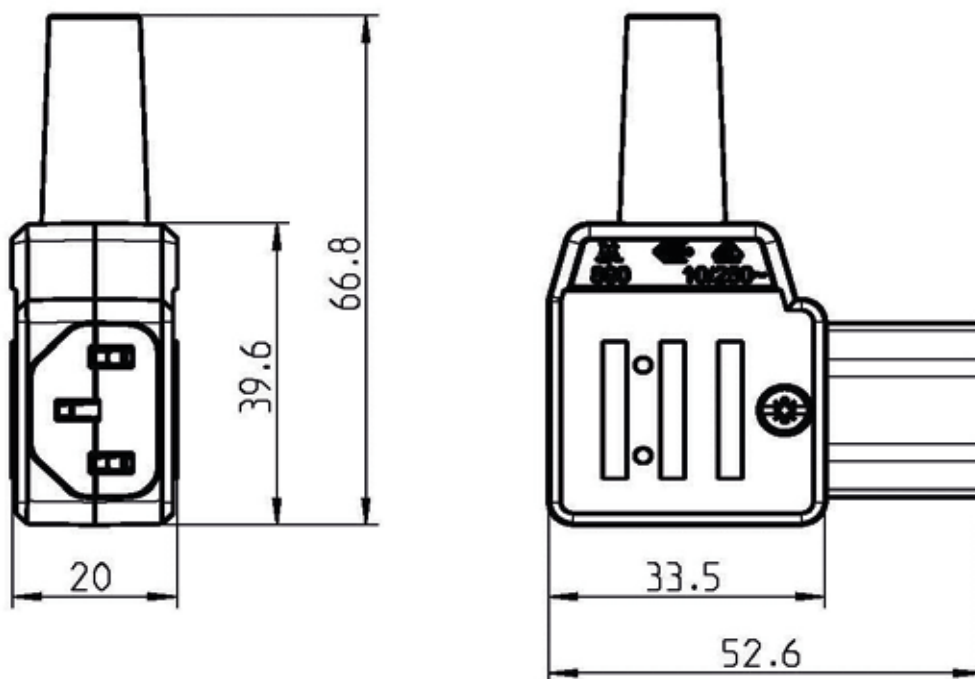

Abisolierung / Wire stripping :

N 35 mm L 25 mm PE 50 mm